

EMCO®
WHEATON RETAIL

A1004-215

Double Wall Spill Containment

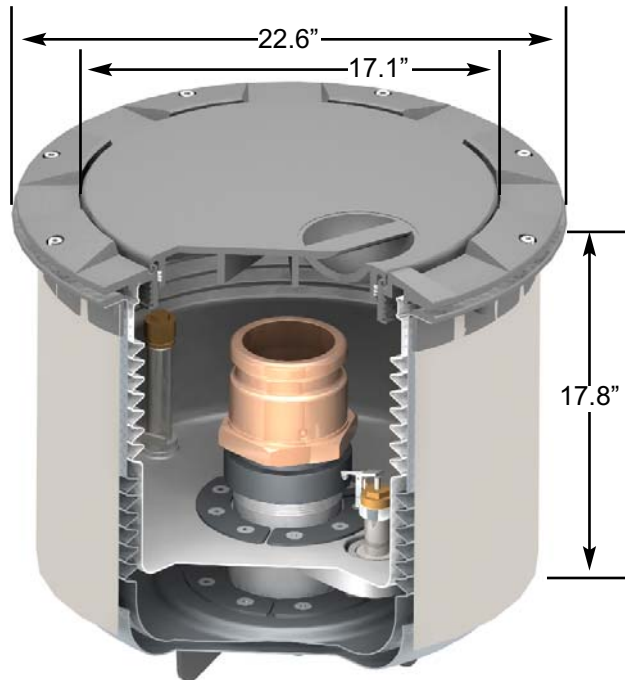

New!!

**15 Gallon
Double Wall
Spill Containment**

- Upper rim assembly, primary and secondary units are easily replaceable *without breaking concrete*
- Ideal for use with shallow bury tanks
- Factory assembled and tested - shipped as a complete unit
- Interstitial space is sealed and testable
- Ductile iron lid and rim offer greater strength
- Side seal lid design is water-resistant

Emco Wheaton Retail Corporation

2300 Industrial Park Drive • Wilson, North Carolina 27893
252-243-0150 • 252-243-4603 (fax) • www.emcoretail.com