

Easily and quickly upgrade your leaking spill containment manholes

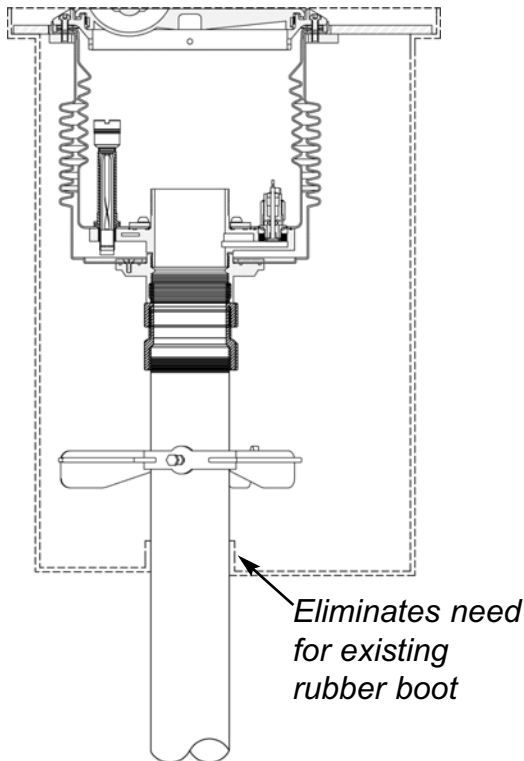

- Never break concrete
- Use existing riser pipe
- No more rubber boot
- *eliminates leaking*
- Built-in pressure relief valve
- Includes the Emco **EZ-Gage**
Quickly and easily check liquid levels - displays green for OK; red if testing is required

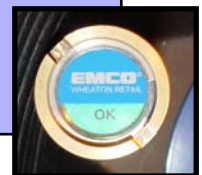

Model No.	Description	Replaces	Drain
A1004-316RH5	DoubleSpill, 5 gallon, 16" center	OPW 500 Series	Drain
A1004-317RH5	DoubleSpill, 5 gallon, 16" center	OPW 500 Series	No Drain
A1004-316RH7	DoubleSpill, 5 gallon, 16" center	OPW 700 Series	Drain
A1004-317RH7	DoubleSpill, 5 gallon, 16" center	OPW 700 Series	No Drain
A1004-316RSX5	DoubleSpill, 5 gallon, 16" center	OPW 500 Series	Drain
A1004-317RSX5	DoubleSpill, 5 gallon, 16" center	OPW 500 Series	No Drain
A1004-316RSX7	DoubleSpill, 5 gallon, 16" center	OPW 700 Series	Drain
A1004-317RSX7	DoubleSpill, 5 gallon, 16" center	OPW 700 Series	No Drain

"X" variants include the A0030-124S Swivel Fill Adapter and A0097-005 Fill Cap