

*The Only Phase I EVR Approved
15 Gallon Double Wall*

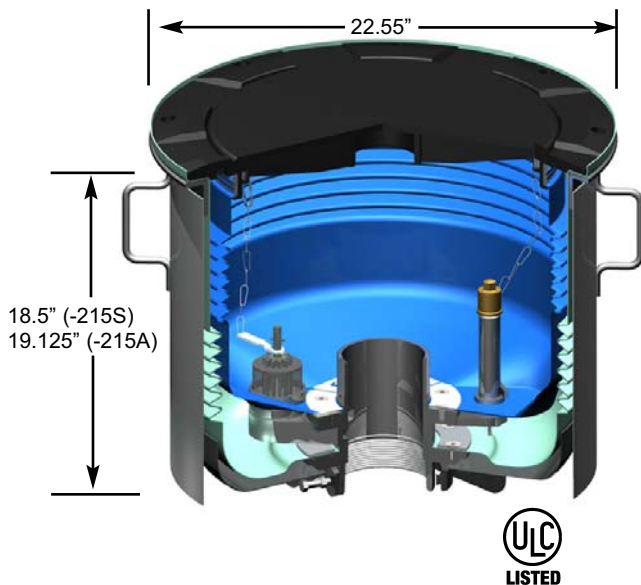

- Never break concrete
- Available in single wall and double wall versions
- Easily repair or replace primary and secondary units from grade without breaking concrete
- Includes male nipple - eliminates an extra joint
- One piece bellows with bolted flange seals, eliminates screw clamp, sealing in critical containment areas
- Vacuum testable at grade level
- Water-resistant lid with built-in handle and exclusive triple wiper seal, meets H20 load rating

Protect your site

The average amount of fuel contained in the tanker's hose during a fuel drop is 13.4 gallons. Make sure you have the #1 double wall to fully meet this capacity.

Model No.	Description	Drain
A1004EVR-215A	Single Wall	Drain
A1004EVR-216A	Single Wall	No Drain
A1004EVR-215S	DoubleSpill	Drain
A1004EVR-216S	DoubleSpill	No Drain
A1004-215S-CM	DoubleSpill w/Sensor	Drain

Approvals

ULC	MH21149
Florida	EQ695
CARB	To be listed under EVR VR-105-C
North Carolina	Meets all requirements for double wall spill containment