

EMCO®
WHEATON RETAIL

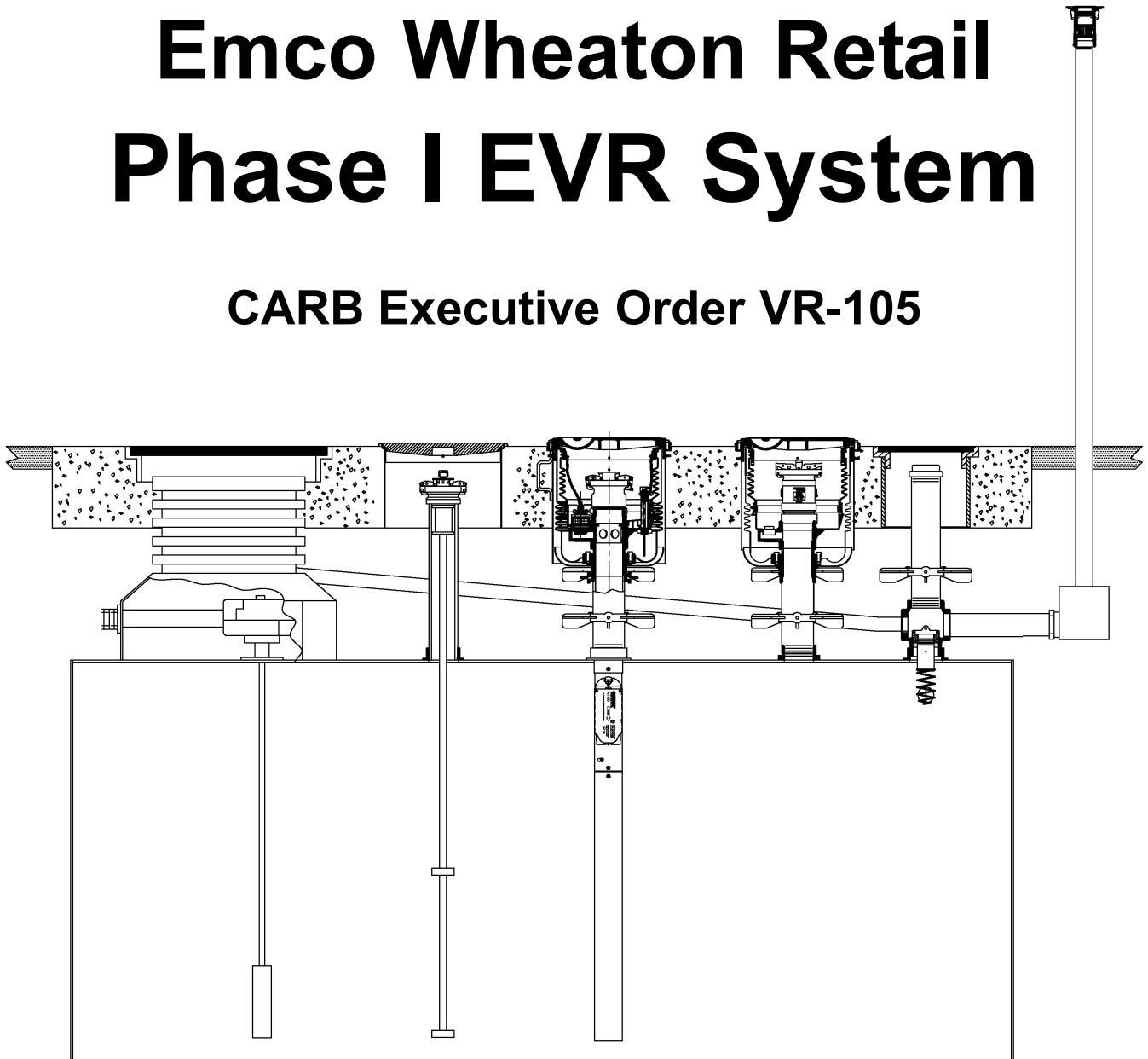

Emco Wheaton Retail Phase I EVR System

CARB Executive Order VR-105



EMCO WHEATON RETAIL CORPORATION

2300 Industrial Park Drive • Wilson, North Carolina 27893
252-243-0150 • 252-243-4603 (fax) • www.emcoretail.com

A1004EVR-210 Series

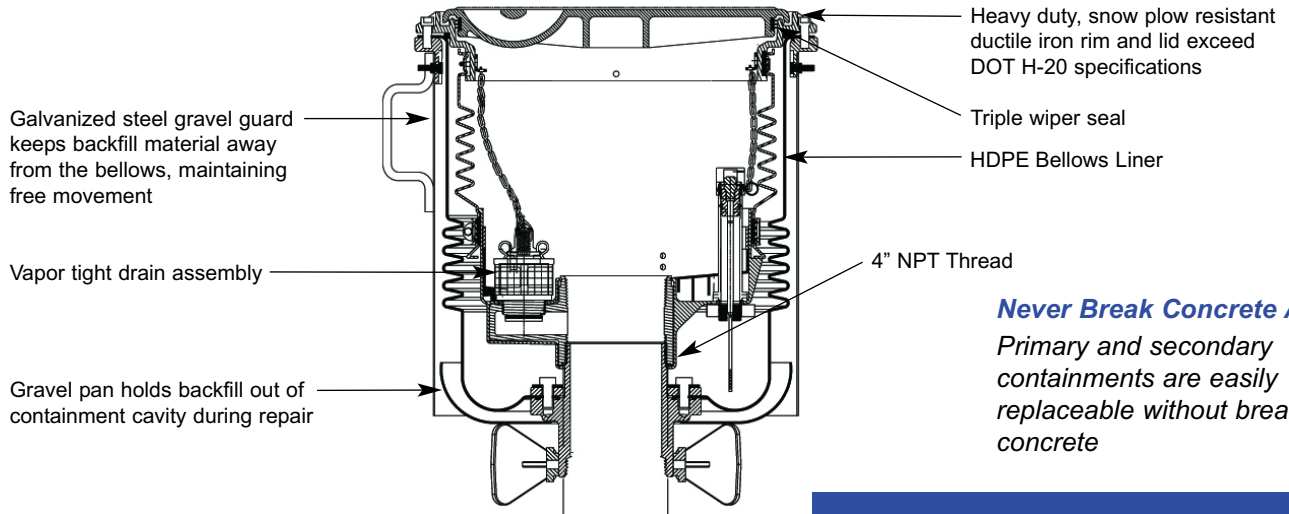

Never Break Concrete Again
Primary and secondary containments are easily replaceable without breaking concrete

Replacement Parts

493806	Lid & Seal, 6 gal
494118	Pull/Push Drain Valve Kit w/Filter
494360EVR	-210A Primary Repair Kit
494466EVR	-211A Primary Repair Kit
494350EVR	-210S Primary Repair Kit
494467EVR	-211S Primary Repair Kit
494344EVR	-210S Secondary Repair Kit
494554	Lid & Seal, 15 gal
494602EVR	-215A Primary Repair Kit
494461EVR	-216A Primary Repair Kit
494550EVR	-215S Primary Repair Kit
494660EVR	-216S Primary Repair Kit
494552EVR	-215S Secondary Repair Kit

A1004EVR-010 Series

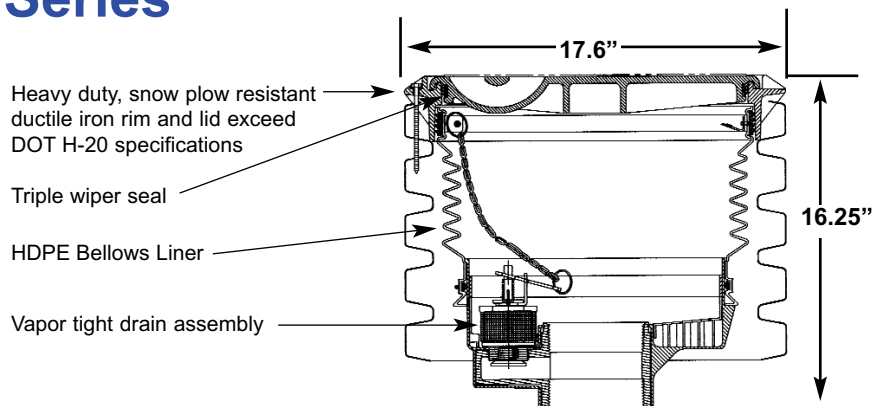

Model No.	Description	Rim Diameter	Total Weight	Drain Type
A1004EVR-010	Slimline, 6 gallons	17.6"	56.0 lbs.	Pull/Push
A1004EVR-011	Slimline, 6 gallons	17.6"	56.0 lbs.	None

Replacement Parts

493806	Lid & Seal, 5 gal
494118	Pull/Push Drain Valve Kit w/Filter

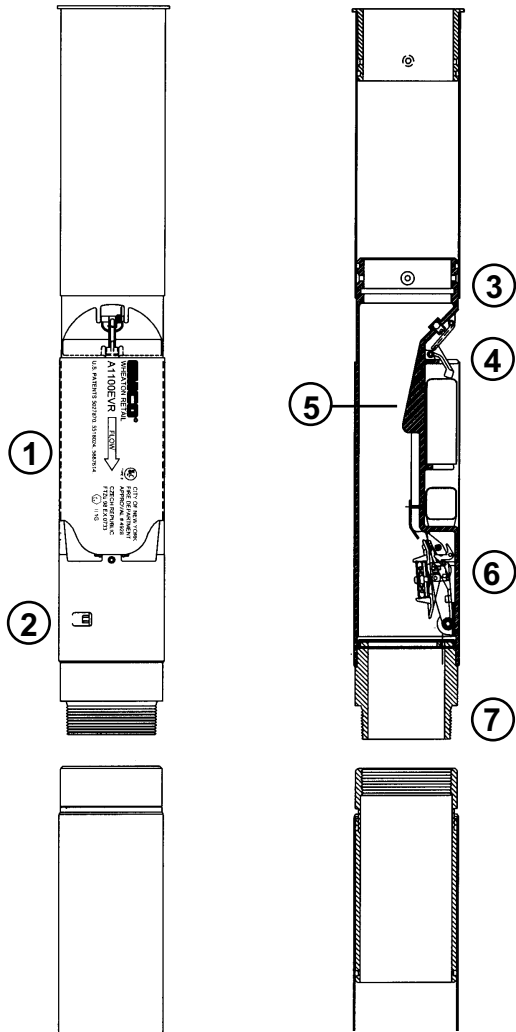

Provides tank with automatic fuel shutoff at 95% capacity

- 1 Floats contained in protective sleeve**
Insures damage-free installation & removal. No hinged legs or exposed floats to hang up.
 - 2 Plug socket**
Allows manual testing of flapper valve assembly in field.
 - 3 Top tube-to-valve interface factory welded, sealed and tested** for vapor-tight performance.
 - 4 Secondary float bleed valve with Viton[®] seal**
Allows fast hose drainage.
 - 5 Diverter fins protect the flapper valve**
Allows damage-free stick gauging at any fluid level.
 - 6 Automatic valve resetting function**
Positions flapper out of the flow stream. Allows immediate stick gauging after fill.
 - 7 Base of overfill valve is threaded and factory welded to bottom tube incorporating Viton[®] seals** for vapor-tight performance.
- Aluminum body, HDPE floats, Viton[®] seals
 - Straight through design gives highest flow rate
 - Compatible with all standard fuels

Viton[®] is a registered trademark of DuPont Dow Elastomers.

Model No.	Description	Overall Length	Max. Riser Length	Nominal Tank Dia.	Weight
A1100EVR-055	Dual Point	13 ft.	4.6 ft.	8 ft.	22 lbs.
A1100EVR-056	Dual Point	15 ft.	5.5 ft.	10 ft.	24 lbs.
A1100EVR-057	Dual Point	18 ft.	6.2 ft.	12 ft.	27 lbs.
A1100EVR-058	Dual Point	21 ft.	9.5 ft.	12 ft.	30 lbs.

The A1100 OPV is not recommended for tanks under 6.5' in diameter.

A0020EVR Drop Tube

Fits directly into the tank riser pipe to permit tight fill submerged filling with reduced turbulence and minimal vapor loss. 4" diameter, aluminum construction.

Model No.	Length
A0020EVRC-004	12'
A0020EVRC-005	15'
A0020EVRC-007	17'
A0020EVRC-008	14'

Replacement Parts

Drop Tube O-ring 569461





A0030-124S Swivel Fill Adapter

A 360° rotation prevents loosening of the adapter from the riser pipe. Complies with the EVR allowable maximum: 108 inch-pounds average static torque and 360° rotation. Field serviceable with o-ring kit 494301 and gasket kit 409628.



A0097-005 Fill Adapter Cap

Provides vapor tight integrity, eliminating fugitive emissions. Complies with CARB cam and groove performance standard.



A0076-124S Swivel Vapor Adapter

A 360° rotation prevents loosening of the adapter from the riser pipe. Complies with the EVR allowable maximum: 108 inch-pounds average static torque and 360° rotation. Field serviceable with o-ring kit 494301 and gasket kit 409628.



A0099-002 Vapor Adapter Cap

Provides vapor tight integrity, eliminating fugitive emissions. Complies with CARB cam and groove performance standard.



A0030-014 ATG Adapter

For use with automatic tank gauge probes.

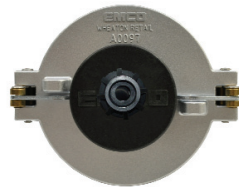

A0097-010 ATG Probe Adapter Cap

Provides vapor tight integrity, eliminating fugitive emissions. Complies with CARB cam and groove performance standard. Leak tight cable connector.



A0079 Extractor Fitting

The A0079 Extractor Fitting attaches tank vent lines and provides multiple outlets used to manifold tank vents or accommodate vapor return lines from dispensers. The A0079 is available with a variety of port combinations. The A0079 is also available without an extractor cage for applications that do not require the use of a ball float and is an economical alternative for direct manifold systems.



A0075 Ball Float

The A0075 Ball Float is designed to restrict product flow in the event of a UST overflow.



494096 Riser Seal Assembly

Provides threaded pressure to seal the drop tube to the top of the fill riser, allowing the standing fuel and/or water to drain into the drop tube instead of the tank ullage. This eliminates a path for vapor emissions and complies with CARB Procedure CP-201 and all applicable CARB test procedures.

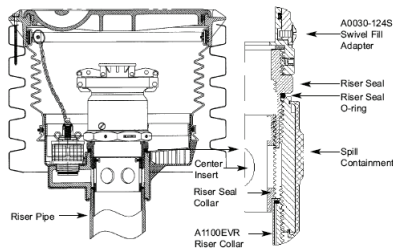

A0081-001C Swivel Adapter Wrench



494240 Swivel Adapter Torque Wrench



494120 Riser Seal Wrench



494241 Spill Containment Wrench



566675 A1100 Drill Fixture



493820EVR Drain Wrench



A0560 Extractor Wrench

Installation and Maintenance Tools